

Tipo - PFL - Cargas Normais

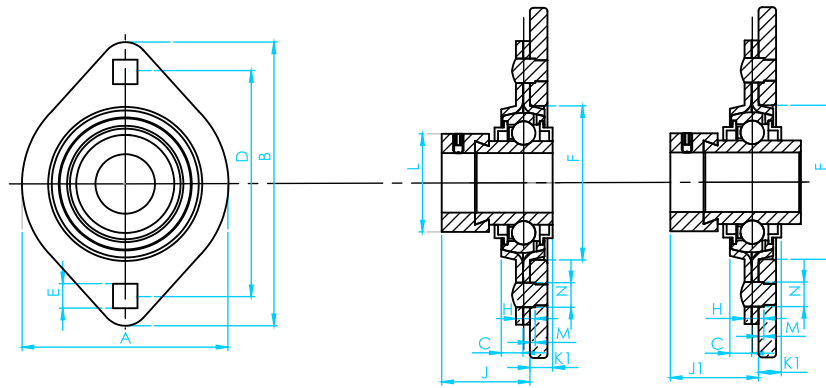

BRM

Eixo		Mancal	A	B	E	D	E largura do furo	F	H	J	J1	K	K1	L	Ø do Paraf.	M	
mm	Pol.															HASTE CURTA	HASTE LONGA
12 15	1/2 5/8	PFL203	58,73	80,96	7,14	63,5	7,14	49,21	1,9	25,4	23,81	11,91	4,76	28,58	6,35	0,15	2,54
17 20	3/4	PFL204	66,67	90,48	7,93	71,44	8,73	55,56	2,1	28,57	25,4	15,08	5,55	33,34	7,93	0,53	2,92
25	7/8 15/16 1	PFL205	71,04	95,25	8,73	76,2	8,73	60,32	2,1	28,97	25,4	15,48	5,55	38,1	7,93	0,53	2,92
30	1 1/16 1 1/8 1 3/16 1 1/4S	PFL206	84,13	112,71	8,73	90,49	10,31	71,43	2,64	32,94	29,36	15,48	6,35	44,45	9,52	0,27	2,64
35	1 1/4 1 5/16 1 3/8 1 7/16	PFL207	93,66	125,41	11,11	100	10,31	80,96	2,64	34,92	32,14	16,27	6,74	55,56	9,52	0,27	2,64

Tipo - PF - Cargas Normais

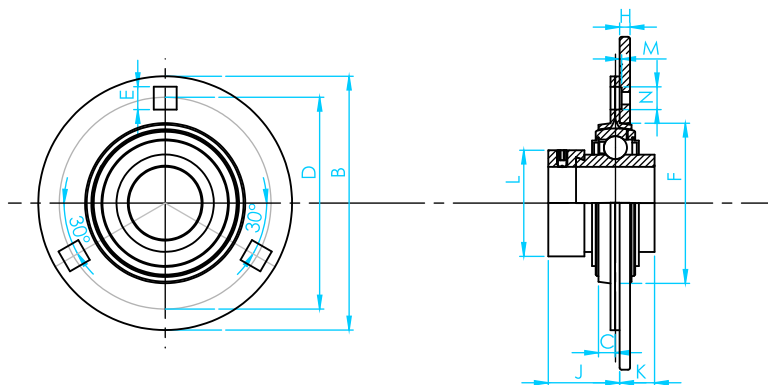

BRM

Eixo		Mancal	B mm	C mm	D mm	E largura do furo mm	F mm	H mm	J mm	K mm	L mm	Ø do Paraf.	M	
mm	Pol.												HASTE CURTA	HASTE LONGA
12 15 17	1/2 5/8	PF203	80,96	7,14	63,5	2,38	182,56	1,9	25,4	11,9	28,57	1/4	.006	.100
20	3/4	PF204	90,48	7,93	71,43	8,73	55,56	2,1	28,57	15,08	33,33	5/16	.021	.115
25	7/8 15/16 1	PF205	95,25	8,73	1	8,73	60,32	2,1	28,97	15,47	38,1	5/16	.021	.115
30	1 1/8 1 3/16 1 1/4	PF206	112,71	8,73	90,48	10,32	71,43	2,64	32,54	15,87	44,45	3/8	.011	.104
35	1 1/4 1 5/16 1 3/8 1 7/16	PF207	112,23	9,52	100	10,32	80,96	2,64	34,92	16,27	55,56	3/8	.011	.104
40	1 1/2 1 9/16	PF208	147,63	10,31	119,06	13,49	90,48	3,4	38,1	18,25	60,32	1/2	.013	.107
45	1 5/8 1 11/16	PF209	149,22	11,11	120,65	13,49	96,83	34,03	38,1	18,25	63,5	1/2	.013	.107
50	1 7/8 1 15/16	PF210	155,57	11,11	127	13,49	101,6	3,78	42,06	20,63	69,85	1/2	.000	.077
55	2 2 1/8 2 3/16	PF211	166,68	11,9	138,1	13,4	112,71	3,78	47,62	23,81	76,2	1/2	.000	.077

Tipo - PP - Cargas Normais

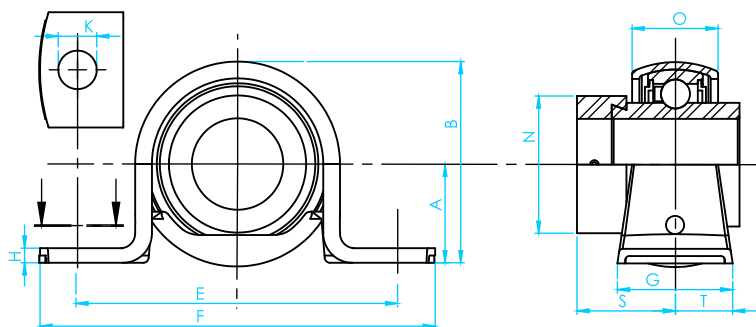

BRM

Código do conjunto	Polegadas												Rolamento nº	Mancal nº	Cap da carga Radial do Mancal
	A	B	E	F	G	H	J	K	N	O	S	T			
PP 1/2	7/8	1 23/32	2 11/16	3 3/8	1	.100	3/8	13/32	1 1/8	.718	.869	1/2	SA201 008	PP203	300 lbf
PP 5/8													SA202 010		
PP 11/16													SA203 11		
PP 3/4	1	1 63/64	3	3 7/8	1 1/4	.100	3/8	13/32	1 5/16	.859	12/13	5/8	SA204 12	PP204	350 lbf
PP 13/16	1 1/8	2 13/64	3 3/8	4 1/4	1 1/4	.112	7/16	15/32	1 1/2	.859	.923	5/8	SA205 13	PP205	400 lbf
PP 7/8													SA205 14		
PP 15/16													SA205 15		
PP 1													SA205 16		
PP 11/16	1 5/16	2 19/32	3 3/4	4 5/8	1 1/2	.145	7/16	15/32	1 3/4	1,000	1,052	3/4	SA206 17	PP206	600 lbf
PP 1 1/8													SA206 18		
PP 13/16													SA206 19		
PP 1 1/4S													SA206 20		

Tipo - RPB - Cargas Normais

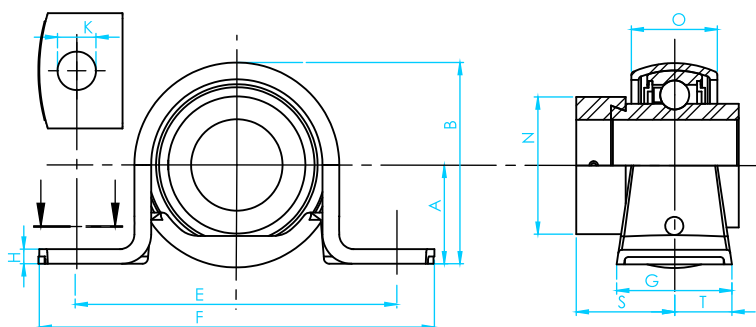

BRM

Código do conjunto	Polegadas												Rolamento nº	Mancal nº	Cap da carga Radial do Mancal
	A	B	E	F	G	H	J	K	N	O	S	T			
RPB 1/2	1	1 63/64	3	3 7/8	1 1/4	.100	3/8	13/32	1 1/8	.850	.869	5/8	SA201 008	PP204	200 lbf
RPB 9/16													SA202 010		
RPB 5/16													SA203 11		
RPB 3/4	1 1/8	2 13/16	3 3/4	4 5/8	1 1/2	.112	7/16	15/32	1 5/16	.850	.923	5/8	SA204 12	PP205	250 lbf
RPB 13/16	1 5/16	2 19/32	3 3/4	4 5/8	1 1/2	.145	7/16	15/32	1 1/2	1,000	.923	3/4	SA205 13	PP206	300 lbf
RPB 7/8													SA205 14		
RPB 15/16													SA205 15		
RPB 1													SA205 16		